

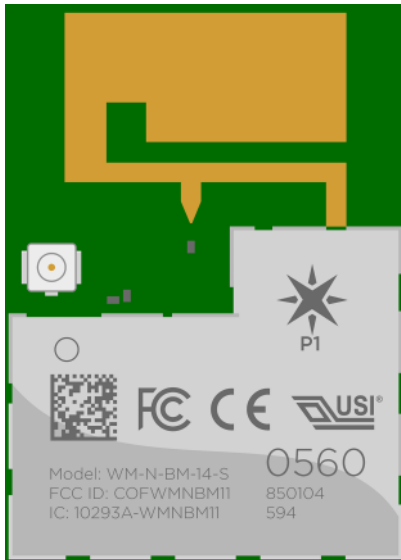

[Guide](#) [Reference](#) [Datasheets](#) [Support](#)
[Datasheets](#)
[Edit](#)

- [Particle Kits Overview](#)
- [Particle shields and kits](#)
- [Electron datasheet](#)
- [Photon datasheet](#)
- [P1 datasheet](#)
- [Functional description](#)
- [Interfaces](#)
- [Memory Map](#)
- [Pin and button definition](#)
- [Technical specification](#)
- [Absolute maximum ratings](#)
- [Recommended operating conditions](#)
- [Wi-Fi Specifications](#)
- [I/O Characteristics](#)
- [Mechanical specifications](#)
- [P1 Reference Design Schematic](#)
- [P1 Reference Design Layout](#)
- [Recommended solder reflow profile](#)
- [Ordering information](#)
- [Qualification and approvals](#)
- [Product handling](#)
- [Default settings](#)
- [Glossary](#)
- [FCC IC CE Warnings and End Product Labeling Requirements](#)
- [Revision history](#)
- [Known Errata](#)
- [Contact](#)
- [Core datasheet](#)
- [Core shields and kits](#)

P1 Datasheet (v005)



```
void setup() {  
  Particle.publish("my-event", "The internet just got smarter!");  
}
```

Functional description

Overview

The P1 is Particle's tiny Wi-Fi module that contains both the Broadcom Wi-Fi chip and a reprogrammable STM32F205RGY6 32-bit ARM Cortex-M3 microcontroller. The P1 comes preloaded with Particle firmware libraries, just like our dev kits, and it's designed to simplify your transition from prototype to production. The P1 is the P0's big brother; it's a bit bigger and a tad more expensive, but it includes some extra flash and an antenna and u.FL connector on board. Every P1 includes free cloud service.

Features

- Particle P1 Wi-Fi module
- Broadcom BCM43362 Wi-Fi chip
- 802.11b/g/n Wi-Fi
- STM32F205RGY6 120Mhz ARM Cortex M3
- 1MB flash, 128KB RAM
- 1MB external SPI flash
- Integrated PCB antenna
- Integrated u.FL connector for external antenna
- Integrated RF switch
- 25 Mixed-signal GPIO and advanced peripherals
- Open source design
- Real-time operating system (FreeRTOS)
- Soft AP setup
- FCC, CE and IC certified

Interfaces

Block Diagram

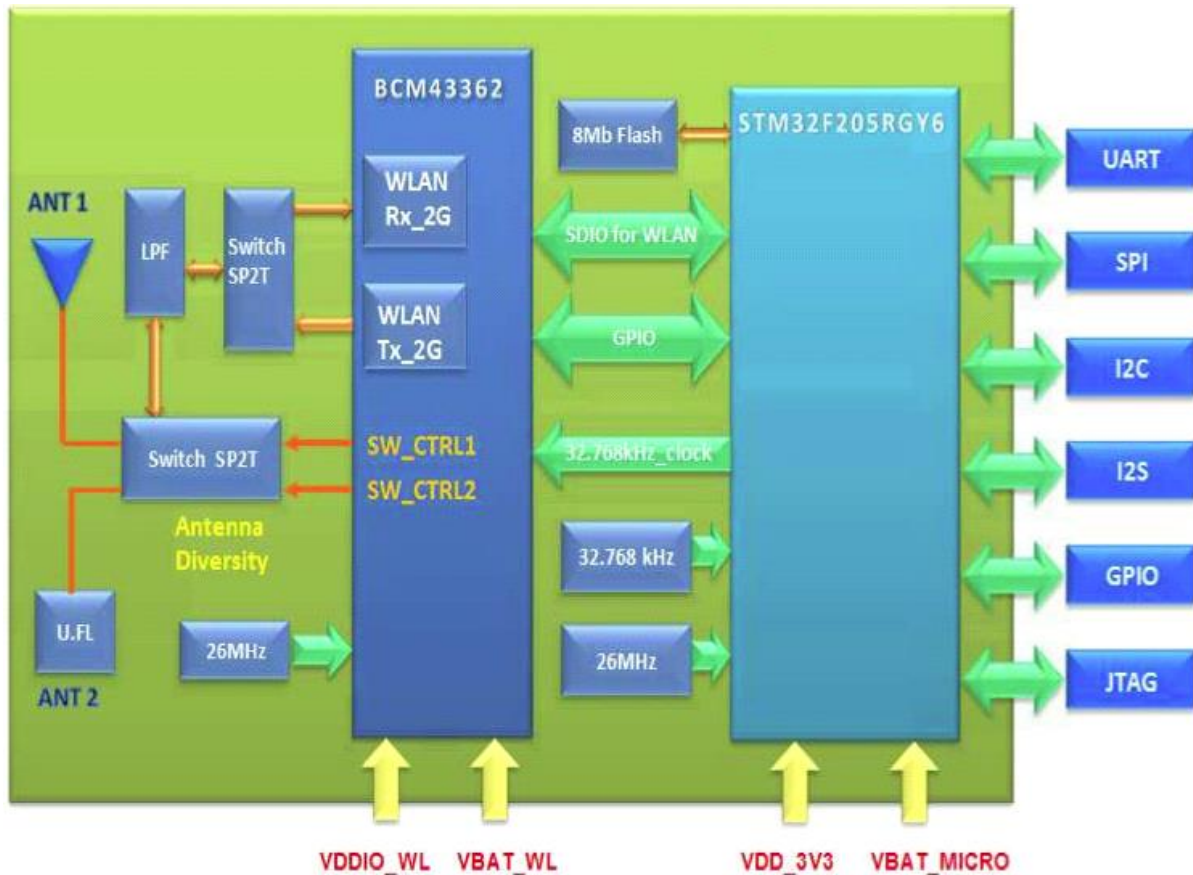

Power

Power to the P1 is supplied via 3 different inputs: VBAT_WL (pin 2 & 3), VDDIO_3V3_WL (pin 5), VDD_3V3 (pin 26 & 27). Optionally +3.3V may be supplied to VBAT_MICRO (pin 38) for data retention in low power sleep modes. Each of these inputs also requires a 0.1uF and 10uF ceramic decoupling capacitor, located as close as possible to the pin (see Fig 1). The voltage should be regulated between 3.0VDC and 3.6VDC.

Typical average current consumption is 80mA with 5V @ input of the recommended SMPS power supply with Wi-Fi on. Deep sleep quiescent current is typically 80uA (Please refer to [Recommended Operating Conditions](#) for more info). When powering the P1 make sure the power supply can handle 600mA continuous. If a lesser power supply is provided, peak currents drawn from the P1 when transmitting and receiving will result in voltage sag at the input which may cause a system brown out or intermittent operation. Likewise, the power source should be sufficient enough to source 1A of current to be on the safe side.

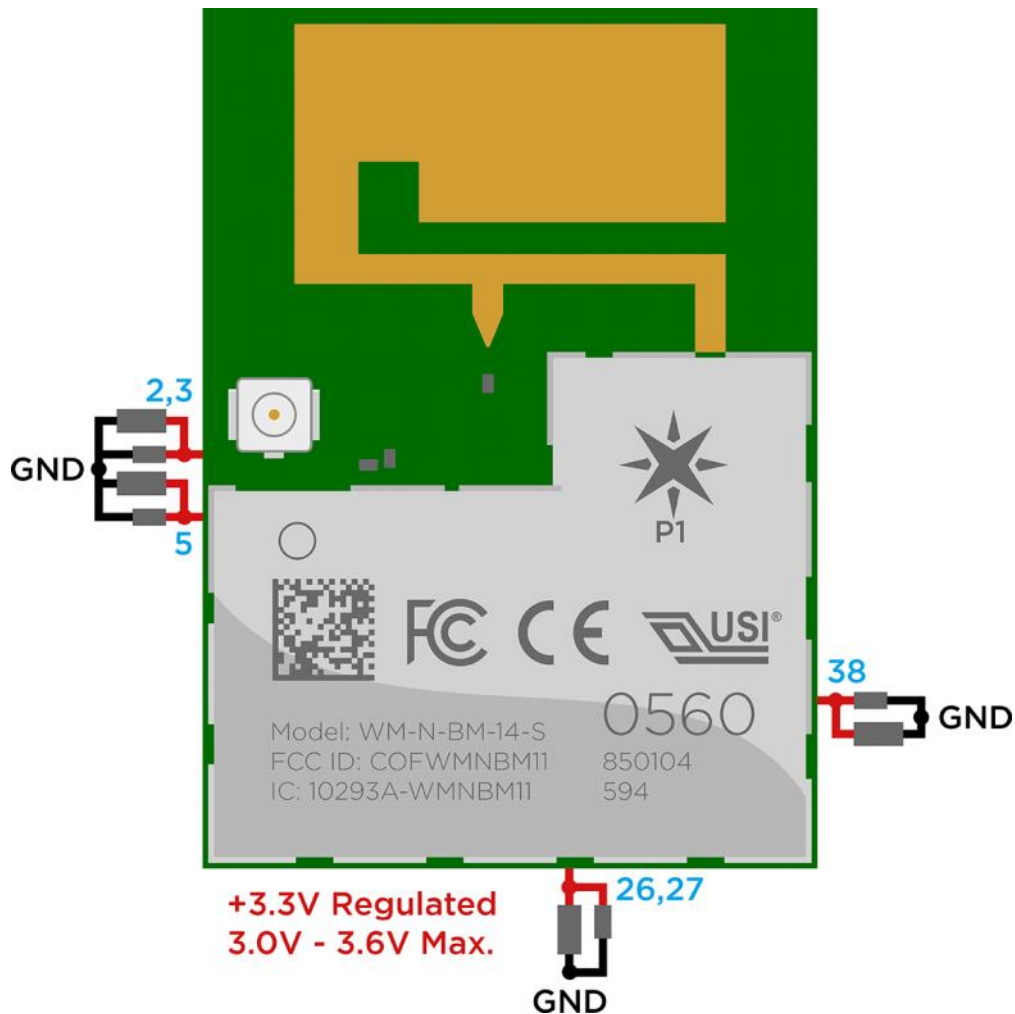

Fig. 1 Recommended power connections with decoupling capacitors.
RF

The RF section of the P1 includes an on-board PCB trace antenna and a u.FL connector which allows the user to connect an external antenna. These two antenna outputs are selectable via a user API, made possible by an integrated RF switch.

The default selected antenna will be the PCB antenna.

The area surrounding the PCB antenna on the carrier PCB should be free of ground planes and signal traces for maximum Wi-Fi performance.

FCC Approved Antennas

Antenna Type	Manufacturer	MFG. Part #	Gain
Dipole antenna	LumenRadio	104-1001	2.15dBi
PCB Antenna	Included	-	-

Peripherals and GPIO

The P1 module has ton of capability in a super small footprint, with analog, digital and communication interfaces.

Note: P1 pin names will be preserved as they are named in the USI datasheet, however for the scope of this datasheet we will also refer to them as their Photon and code equivalents, i.e. D7 instead of MICRO_JTAG_TMS and A2 instead of MICRO_GPIO_13. This will help to simplify descriptions, while providing

a quick reference for code that can be written for the P1 such as `int value = analogRead(A2);`

Peripheral Type	Qty	Input(I) / Output(O)	FT[1] / 3V3[2]
Digital	24	I/O	FT/3V3
Analog (ADC)	13	I	3V3
Analog (DAC)	2	O	3V3
SPI	2	I/O	3V3
I2S	1	I/O	3V3
I2C	1	I/O	FT
CAN	1	I/O	FT
USB	1	I/O	3V3
PWM	113	O	3V3

Notes:

[1] FT = 5.0V tolerant pins. All pins except A3 and DAC are 5V tolerant (when not in analog mode). If used as a 5V input the pull-up/pull-down resistor must be disabled.

[2] 3V3 = 3.3V max pins.

[3] PWM is available on D0, D1, D2, D3, A4, A5, WKP, RX, TX, P1S0, P1S1 with a caveat: PWM timer peripheral is duplicated on two pins (A5/D2) and (A4/D3) for 7 total independent PWM outputs. For example: PWM may be used on A5 while D2 is used as a GPIO, or D2 as a PWM while A5 is used as an analog input. However A5 and D2 cannot be used as independently controlled PWM outputs at the same time.

RGB LED, SETUP and RESET button

When using the P1 module, it is very important to remember that your device must have an RGB LED to show the user the connectivity status. Also required is a SETUP and RESET button to enter various [Device Modes](#). By default the RGB LED outputs are configured for a Common Anode type of LED. These components should be wired according to the [P1 Reference Design - User I/O](#). RGB pins may be accessed in code as: RGBR, RGBG and RGBB.

JTAG and SWD

Pin D3 through D7 are JTAG interface pins. These can be used to reprogram your P1 bootloader or user firmware image with standard JTAG tools such as the ST-Link v2, J-Link, R-Link, OLIMEX ARM-USB-TINI-H, and also the FTDI-based Particle JTAG Programmer. If you are short on available pins, you may also use SWD mode which requires less connections.

Photon Pin	JTAG	SWD	STM32F205RGY6 Pin	P1 Pin #	P1 Pin Name	Default Internal[1]
D7	JTAG_TMS	SWD/SWDIO	PA13	54	MICRO_JTAG_TMS	~40k pull-up
D6	JTAG_TCK	CLK/SWCLK	PA14	55	MICRO_JTAG_TCK	~40k pull-down
D5	JTAG_TDI		PA15	53	MICRO_JTAG_TDI	~40k pull-up
D4	JTAG_TDO		PB3	54	MICRO_JTAG_TDO	Floating
D3	JTAG_TRST		PB4	51	MICRO_JTAG_TRSTN	~40k pull-up
3V3	Power	Power				
GND	Ground	Ground				
RST	Reset	Reset				

Notes: [1] Default state after reset for a short period of time before these pins are restored to GPIO (if JTAG debugging is not required, i.e. `USE_SWD_JTAG=y` is not specified on the command line.)

A standard 20-pin 0.1" shrouded male JTAG interface connector should be wired as follows:

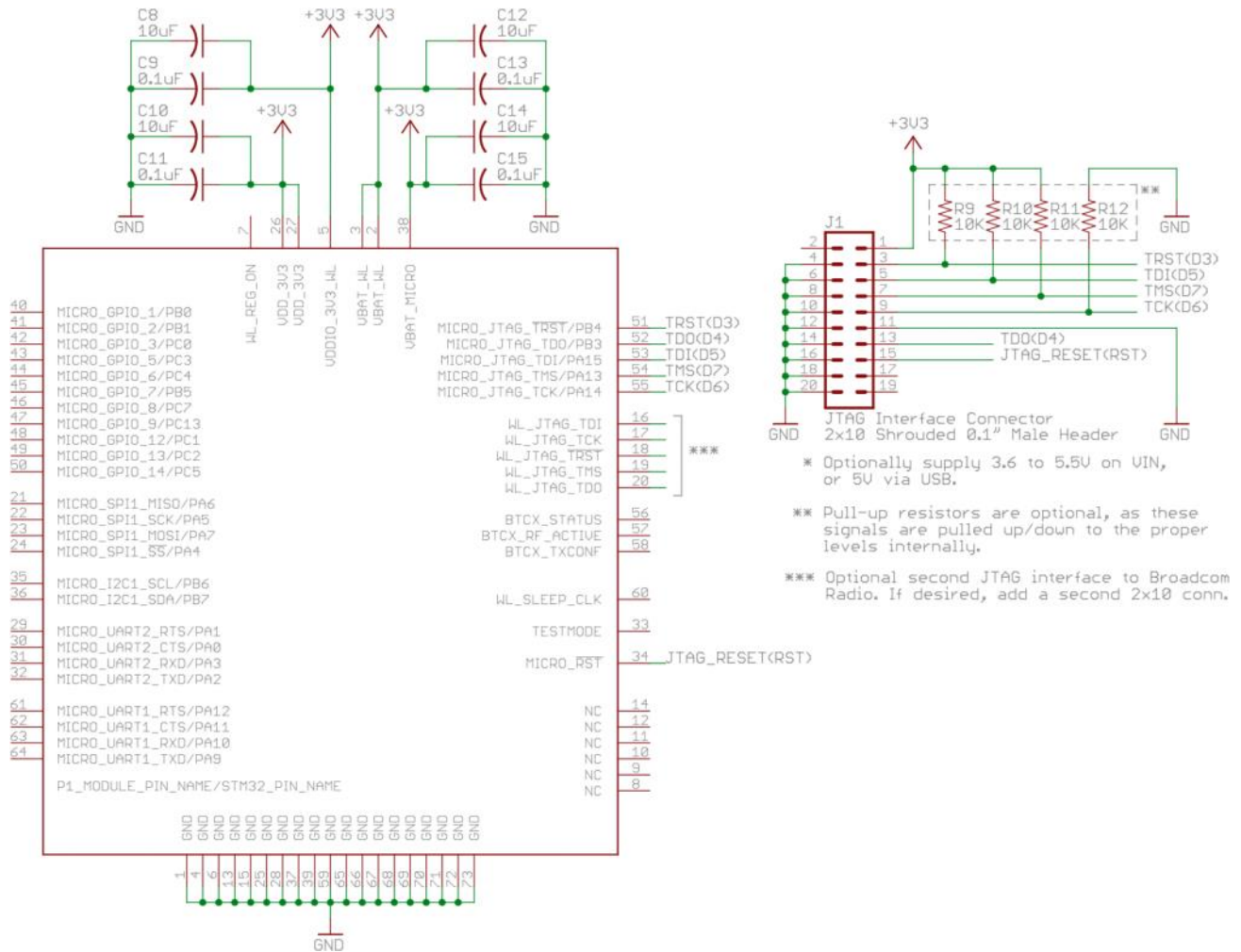

[\(click to stop squinting\)](#)

External Coexistence Interface

The P1 supports coexistence with Bluetooth and other external radios via three pins available on the P1 module.

When two radios occupying the same frequency band are used in the same system, such as Wi-Fi and Bluetooth, a coexistence interface can be used to coordinate transmit activity, to ensure optimal performance by arbitrating conflicts between the two radios.

P1 Pin Name	P1 Pin #	I/O	Description
BTCX_RF_ACTIVE	57	I	Coexistence signal: Bluetooth is active
BTCX_STATUS	56	I	Coexistence signal: Bluetooth priority status and TX/RX direction
BTCX_TXCONF	58	O	Output giving Bluetooth permission to TX

When these pins are programmed to be used as a Bluetooth coexistence interface, they're set as high impedance on power up and reset.

Memory Map

STM32F205RGY6 Flash Layout Overview

- Bootloader (16 KB)
- DCT1 (16 KB), stores Wi-Fi credentials, keys, mfg info, system flags, etc..
- DCT2 (16 KB), swap area for DCT1
- EEPROM emulation bank 1 (16 KB)
- EEPROM emulation bank 2 (64 KB) [only 16k used]
- System firmware (512 KB) [256 KB Wi-Fi/comms + 256 KB hal/platform/services]

- Factory backup, OTA backup and user application (384 KB) [3 x 128 KB]

DCT Layout

The DCT area of flash memory has been mapped to a separate DFU media device so that we can incrementally update the application data. This allows one item (say, server public key) to be updated without erasing the other items.

DCT layout as of v0.4.9 [found here in firmware](#)

Region	Offset	Size
system flags	0	32
version	32	2
device private key	34	1216
device public key	1250	384
ip config	1634	128
claim code	1762	63
claimed	1825	1
ssid prefix	1826	26
device id	1852	6
version string	1858	32
dns resolve	1890	128
reserved1	2018	64
server public key	2082	768
padding	2850	2
flash modules	2852	100
product store	2952	24
antenna selection	2976	1
cloud transport	2977	1
alt device public key	2978	128
alt device private key	3106	192
alt server public key	3298	192
alt server address	3490	128
reserved2	3618	1280

Note: Writing 0xFF to offset 34 (DEFAULT) or 3106 (ALTERNATE) will cause the device to re-generate a new private key on the next boot. Alternate keys are currently unsupported on the P1 but are used on the Electron as UDP/ECC keys. You should not need to use this feature unless your keys are corrupted.

// Regenerate Default Keys

```
echo -e "\xFF" > fillbyte && dfu-util -d 2b04:d00a -a 1 -s 34 -D fillbyte
```

// Regenerate Alternate Keys

```
echo -e "\xFF" > fillbyte && dfu-util -d 2b04:d00a -a 1 -s 3106 -D fillbyte
```

Memory Map (Common)

Region	Start Address	End Address	Size
Bootloader	0x8000000	0x8004000	16 KB
DCT1	0x8004000	0x8008000	16 KB
DCT2	0x8008000	0x800C000	16 KB
EEPROM1	0x800C000	0x8010000	16 KB
EEPROM2	0x8010000	0x8020000	64 KB

Memory Map (Modular Firmware - default)

Region	Start Address	End Address	Size
System Part 1	0x8020000	0x8060000	256 KB

System Part 2	0x8060000	0x80A0000	256 KB
User Part	0x80A0000	0x80C0000	128 KB
OTA Backup	0x80C0000	0x80E0000	128 KB
Factory Backup	0x80E0000	0x8100000	128 KB

Memory Map (Monolithic Firmware - optional)

Region	Start Address	End Address	Size
Firmware	0x8020000	0x8080000	384 KB
Factory Reset	0x8080000	0x80E0000	384 KB
Unused (factory reset modular)	0x80E0000	0x8100000	128 KB

Pin and button definition

Pin markings

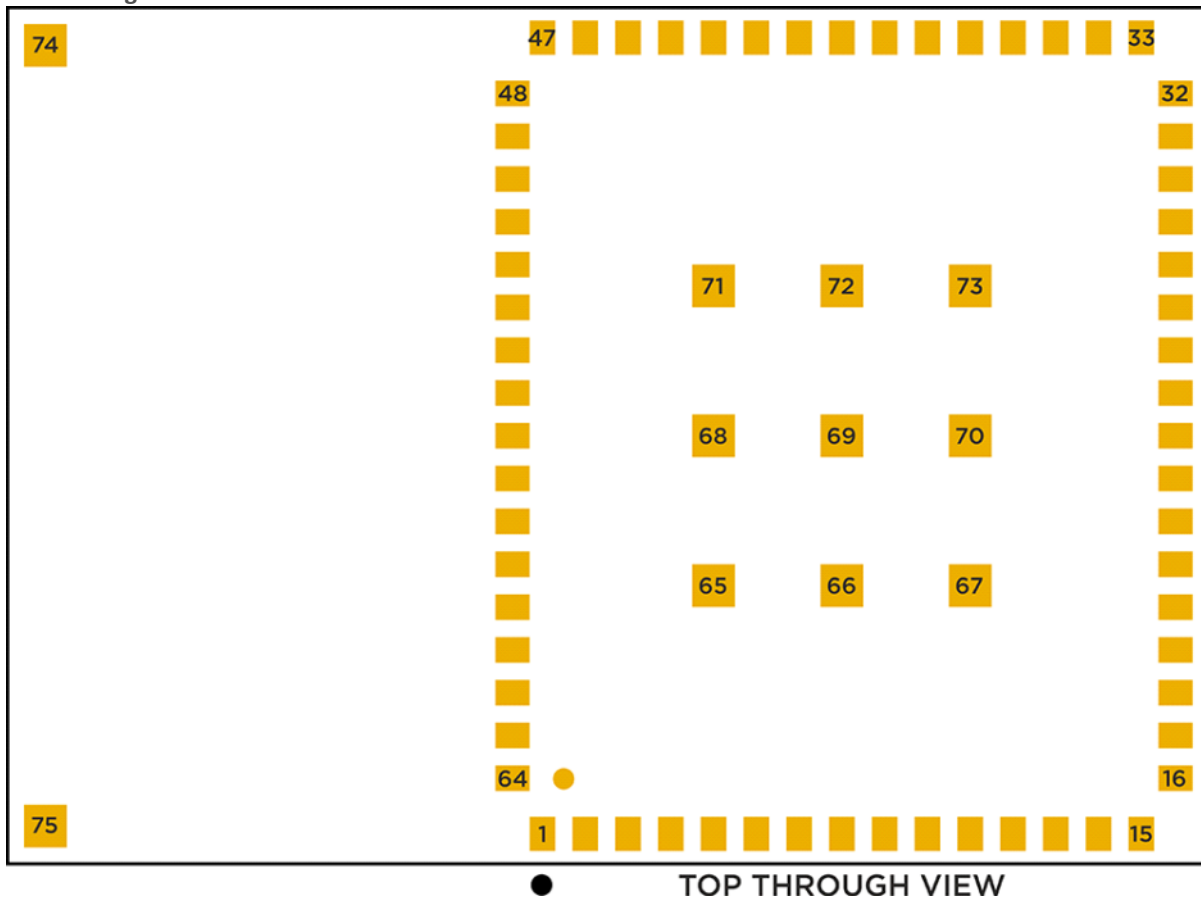

Pin description

Pin	Description
RST	Active-low reset input. On-board circuitry contains a 1k ohm pull-up resistor between RST and 3V3, and 0.1uF capacitor between RST and GND.
VBAT	Supply to the internal RTC, backup registers and SRAM when 3V3 not present (1.65 to 3.6VDC).
3V3	This pin represents the regulated +3.3V DC power to the P1 module. In reality, +3.3V must be supplied to 3 different inputs: VBAT_WL (pin 2 & 3), VDDIO_3V3_WL (pin 5), VDD_3V3 (pin 26 & 27). Optionally +3.3V may be supplied to VBAT_MICRO (pin 38) for data retention in low power sleep modes. Each of these inputs also requires a 0.1uF and 10uF ceramic decoupling capacitor, located as close as possible to the pin.
D0~D7	Digital only GPIO pins. D0~D3 may also be used as a PWM output.
A0~A7	12-bit Analog-to-Digital (A/D) inputs (0-4095), and also digital GPIOs. A6 and A7 are code convenience mappings, which means pins are not actually labeled as such but you may use code like <code>analogRead(A7)</code> . A6 maps to the DAC pin and A7 maps to the WKP pin. A4,A5,A7 may also be used as a PWM output.
DAC	12-bit Digital-to-Analog (D/A) output (0-4095), and also a digital GPIO. DAC is used as DAC or DAC1 in software, and A3 is a second DAC output used as DAC2 in software.

RX	Primarily used as UART RX, but can also be used as a digital GPIO or PWM.
TX	Primarily used as UART TX, but can also be used as a digital GPIO or PWM.
P1S0	12-bit Analog-to-Digital (A/D) inputs (0-4095), and also can be used as a digital GPIO or PWM.
P1S1	12-bit Analog-to-Digital (A/D) inputs (0-4095), and also can be used as a digital GPIO or PWM.
P1S2	12-bit Analog-to-Digital (A/D) inputs (0-4095), and also can be used as a digital GPIO.
P1S3	12-bit Analog-to-Digital (A/D) inputs (0-4095), and also can be used as a digital GPIO.
P1S4	Primarily used as a digital GPIO.
P1S5	12-bit Analog-to-Digital (A/D) inputs (0-4095), and also can be used as a digital GPIO.

Pin out diagrams

Pin	USB	Exposed Functions	STM32 Pin	P1 Pin #	P1 Pin Name	
P1	VIN	VIN				
	GND	GND				
	TX		USART1_TX TIM1_CH2	PA9	64	MICRO_UART1_TXD
	RX		USART1_RX TIM1_CH3	PA10	63	MICRO_UART1_RXD
	WKP	ADC0	TIM5_CH1	PA0	30	MICRO_UART2_CTS
	DAC	ADC4	DAC1	PA4	24	MICRO_SPI1_SS
	A5	ADC7	SPI1_MOSI TIM3_CH2	PA7	23	MICRO_SPI1_MOSI
	A4	ADC6	SPI1_MISO TIM3_CH1	PA6	21	MICRO_SPI1_MISO
	A3	ADC5	SPI1_SCK DAC2	PA5	22	MICRO_SPI1_SCK
	A2	ADC12	SPI1_SS	PC2	49	MICRO_GPIO_13
	A1	ADC13		PC3	43	MICRO_GPIO_5
	A0	ADC15		PC5	50	MICRO_GPIO_14

<=">

USB	Pin	Exposed Functions	STM32 Pin	P1 Pin #	P1 Pin Name	
P1	3V3	3V3				
	RST	RST	E8	34	MICRO_RST_N	
	VBAT	VBAT	A9	38	VBAT	
	GND	GND				
	D7	JTAG_TMS		PA13	54	MICRO_JTAG_TMS
	D6	JTAG_TCK		PA14	55	MICRO_JTAG_TCK
	D5	JTAG_TDI	SPI3_SS I2S3_WS	PA15	53	MICRO_JTAG_TDI
	D4	JTAG_TDO	SPI3_SCK I2S3_SCK	PB3	52	MICRO_JTAG_TDO
	D3	JTAG_TRST	SPI3_MISO TIM3_CH1	PB4	51	MICRO_JTAG_TRSTN
	D2		SPI3_MOSI CAN2_RX TIM3_CH2 I2S3_SD	PB5	45	MICRO_GPIO_7
	D1	SCL	CAN2_TX TIM4_CH1	PB6	35	MICRO_I2C1_SCL
	D0	SDA	TIM4_CH2	PB7	36	MICRO_I2C1_SDA

<=">

User I/O		Exposed Functions			STM32 Pin	P1 Pin #	P1 Pin Name
P 1	RGB LED - RED		TIM2_CH2		PA1	29	MICRO_UART2_RTS
	RGB LED - GREEN		TIM2_CH3		PA2	32	MICRO_UART2_TXD
	RGB LED - BLUE		TIM2_CH4		PA3	31	MICRO_UART2_RXD
	Setup Button		TIM3_CH2	I2S3_MCK	PC7	46	MICRO_GPIO_8
	Reset Button				E8	34	MICRO_RST_N
	USB Data+				PA12	61	MICRO_UART1_RTS
	USB Data-				PA11	62	MICRO_UART1_CTS
	P1S0	ADC8	TIM3_CH3		PB0	40	MICRO_GPIO_1
	P1S1	ADC9	TIM3_CH4		PB1	41	MICRO_GPIO_2
	P1S2	ADC10			PC0	42	MICRO_GPIO_3
	P1S3	ADC14			PC4	44	MICRO_GPIO_6
	P1S4				PC13	47	MICRO_GPIO_9
	P1S5	ADC11			PC1	48	MICRO_GPIO_12
	Peripheral Key	ADC	SPI	PWM/Servo/Tone			
		JTAG	SPI1	I2S	DAC		
	I2C/Wire	Serial1	CAN				

<="">

Complete P1 Module Pin Listing

P1 Pin #	P1 Pin Name	Type / STM32F205RGY6 Port	Description
1	GND	PWR	Ground
2~3	VBAT_WL	PWR	+3.3V
4	GND	PWR	Ground
5	VDDIO_3V3_WL	PWR	+3.3V
6	GND	PWR	Ground
7	WL_REG_ON	PWR	BCM43362 Debugging Pin
8~12	NC	NC	NC
13	GND	PWR	Ground
14	NC	NC	NC
15	GND	PWR	Ground
16	WL_JTAG_TDI	DEBUG	BCM43362 Debugging Pin
17	WL_JTAG_TCK	DEBUG	BCM43362 Debugging Pin
18	WL_JTAG_TRSTN	DEBUG	BCM43362 Debugging Pin
19	WL_JTAG_TMS	DEBUG	BCM43362 Debugging Pin
20	WL_JTAG_TDO	DEBUG	BCM43362 Debugging Pin
21	MICRO_SPI1_MISO	PA6	A4 (SPI MISO)
22	MICRO_SPI1_SCK	PA5	A3 (SPI SCK)
23	MICRO_SPI1_MOSI	PA7	A5 (SPI MOSI)
24	MICRO_SPI1_SS	PA4	DAC (SPI SS)
25	GND	PWR	Ground
26~27	VDD_3V3	PWR	+3.3V
28	GND	PWR	Ground
29	MICRO_UART2_RTS	PA1	RGBR (RGB LED RED)
30	MICRO_UART2_CTS	PA0	WKP
31	MICRO_UART2_RXD	PA3	RGBB (RGB LED BLUE)

32	MICRO_UART2_TXD	PA2	RGBG (RGB LED GREEN)
33	TESTMODE	PA8	GPIO (see STM32F205RGY6 datasheet)
34	MICRO_RST_N	I	/RESET (Active low MCU reset)
35	MICRO_I2C1_SCL	PB6	D1 (I2C SCL)
36	MICRO_I2C1_SDA	PB7	D0 (I2C SDA)
37	GND	PWR	Ground
38	VBAT_MICRO	PWR	Supply to the internal RTC, backup registers and SRAM when 3V3 not present (1.65 to 3.6VDC)
39	GND	PWR	Ground
40	MICRO_GPIO_1	PB0	P1S0
41	MICRO_GPIO_2	PB1	P1S1
42	MICRO_GPIO_3	PC0	P1S2
43	MICRO_GPIO_5	PC3	A1
44	MICRO_GPIO_6	PC4	P1S3
45	MICRO_GPIO_7	PB5	D2 (I2S SD)
46	MICRO_GPIO_8	PC7	/SETUP (I2S MCK)
47	MICRO_GPIO_9	PC13	P1S4
48	MICRO_GPIO_12	PC1	P1S5
49	MICRO_GPIO_13	PC2	A2
50	MICRO_GPIO_14	PC5	A0
51	MICRO_JTAG_TRSTN	PB4	D3
52	MICRO_JTAG_TDO	PB3	D4 (I2S SCK)
53	MICRO_JTAG_TDI	PA15	D5 (I2S WS)
54	MICRO_JTAG_TMS	PA13	D7
55	MICRO_JTAG_TCK	PA14	D6
56	BTCX_STATUS	I	Coexistence signal: Bluetooth status and TX/RX direction
57	BTCX_RF_ACTIVE	I	Coexistence signal: Bluetooth is active
58	BTCX_TXCONF	O	Output giving Bluetooth permission to TX
59	GND	PWR	Ground
60	WL_SLEEP_CLK	DEBUG	BCM43362 Debugging Pin
61	MICRO_UART1_RTS	PA12	OTG_FS_DP (USB D+)
62	MICRO_UART1_CTS	PA11	OTG_FS_DM (USB D--)
63	MICRO_UART1_RXD	PA10	RX
64	MICRO_UART1_TXD	PA9	TX
65~73	GND	PWR	Ground
74	PAD1	NC	NC
75	PAD2	NC	NC

Technical specification

Absolute maximum ratings

Parameter	Symbol	Min	Typ	Max	Unit
Supply Input Voltage	V3V3-MAX			+3.6	V
Storage Temperature	Tstg	-40		+85	°C
ESD Susceptibility HBM (Human Body Mode)	VESD			2	kV

Recommended operating conditions

Parameter	Symbol	Min	Typ	Max	Unit
Supply Input Voltage	V3V3[1]	+3.0	+3.3	+3.6	V
Supply Input Current (VBAT_WL)	IVBAT_WL			310	mA
Supply Input Current (VDDIO_3V3_WL)	IVDDIO_3V3_WL			50	mA
Supply Input Current (VDD_3V3)	IVDD_3V3			120	mA
Supply Input Voltage	VVBAT_MICRO	+1.65		+3.6	V
Supply Input Current (VBAT_MICRO)	IVBAT_MICRO			19	uA
Operating Current (Wi-Fi on)	I3V3 avg[1]		80	100	mA
Operating Current (Wi-Fi on)	I3V3 pk[1]	235[2]		430[2]	mA
Operating Current (Wi-Fi on, w/powersave)	I3V3 avg[1]		18	100[3]	mA
Operating Current (Wi-Fi off)	I3V3 avg[1]		30	40	mA
Sleep Current (5V @ VIN)	IQs		1	2	mA
Deep Sleep Current (5V @ VIN)	IQds		80	100	uA
Operating Temperature	Top	-20		+60	°C
Humidity Range Non condensing, relative humidity				95	%

Notes:

[1] V3V3 and I3V3 represents the the combined 4 inputs that require +3.3V: VBAT_WL, VDDIO_3V3_WL, VDD_3V3 and VBAT_MICRO.

[2] These numbers represent the extreme range of short peak current bursts when transmitting and receiving in 802.11b/g/n modes at different power levels. Average TX current consumption in will be 80-100mA.

[3] These are very short average current bursts when transmitting and receiving. On average if minimizing frequency of TX/RX events, current consumption in powersave mode will be 18mA

Wi-Fi Specifications

Feature	Description
WLAN Standards	IEEE 802 11b/g/n
Antenna Port	Single Antenna
Frequency Band	2.412GHz -- 2.462GHz (United States of America and Canada)
	2.412GHz -- 2.472GHz (EU)
Sub Channels	1 -- 11 (United States of America and Canada)
	1 -- 13 (EU)
Modulation	DSSS, CCK, OFDM, BPSK, QPSK, 16QAM, 64QAM

P1 module Wi-Fi output power		Typ.	Tol.	Unit
RF Average Output Power, 802.11b CCK Mode	1M	Avail. upon request	+/- 1.5	dBm
	11M	-	+/- 1.5	dBm
RF Average Output Power, 802.11g OFDM Mode	6M	-	+/- 1.5	dBm
	54M	-	+/- 1.5	dBm
RF Average Output Power, 802.11n OFDM Mode	MCS0	-	+/- 1.5	dBm
	MCS7	-	+/- 1.5	dBm

I/O Characteristics

These specifications are based on the STM32F205RGY6 datasheet, with reference to Photon pin

nomenclature.

Parameter	Symbol	Conditions	Min	Typ	Max	Unit
Standard I/O input low level voltage	VIL		-0.3		$0.28*(V3V3-2)+0.8$	V
I/O FT[1] input low level voltage	VIL		-0.3		$0.32*(V3V3-2)+0.75$	V
Standard I/O input high level voltage	VIH		$0.41*(V3V3-2)+1.3$		$V3V3+0.3$	V
I/O FT[1] input high level voltage	VIH	$V3V3 > 2V$	$0.42*(V3V3-2)+1$		5.5	V
	VIH	$V3V3 \leq 2V$	$0.42*(V3V3-2)+1$		5.2	V
Standard I/O Schmitt trigger voltage hysteresis[2]	Vhys		200			mV
I/O FT Schmitt trigger voltage hysteresis[2]	Vhys		5% V3V3[3]			mV
Input/Output current max	lio				± 25	mA
Input/Output current total	lio total				± 120	mA
Input leakage current[4]	llkg	$GND \leq Vio \leq V3V3$ GPIOs			± 1	μA
Input leakage current[4]	llkg	RPU	$Vio = 5V$, I/O FT		3	μA
Weak pull-up equivalent resistor[5]	RPU	$Vio = GND$	30	40	50	k Ω
Weak pull-down equivalent resistor[5]	RPD	$Vio = V3V3$	30	40	50	k Ω
I/O pin capacitance	CIO			5		pF
DAC output voltage (buffers enabled by default)	VDAC		0.2		$V3V3-0.2$	V
DAC output resistive load (buffers enabled by default)	RDAC		5			k Ω
DAC output capacitive load (buffers enabled by default)	CDAC				50	pF

Notes:

[1] FT = Five-volt tolerant. In order to sustain a voltage higher than $V3V3+0.3$ the internal pull-up/pull-down resistors must be disabled.

[2] Hysteresis voltage between Schmitt trigger switching levels. Based on characterization, not tested in production.

[3] With a minimum of 100mV.

[4] Leakage could be higher than max. if negative current is injected on adjacent pins.

[5] Pull-up and pull-down resistors are designed with a true resistance in series with switchable PMOS/NMOS. This PMOS/NMOS contribution to the series resistance is minimum (~10% order).

Mechanical specifications

Overall dimensions

P1 module dimensions are: 0.787"(28mm) (W) x 1.102"(20mm) (L) x 0.0787"(2.0mm) (H) +/-0.0039"(0.1mm) (includes metal shielding)

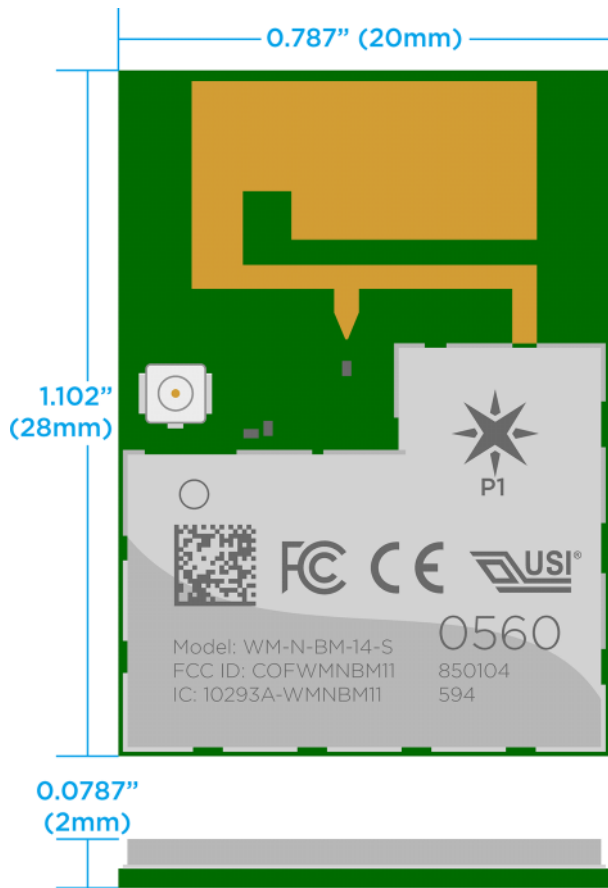

Actual size (so tiny!)
P1 Module Dimensions

These are the physical dimensions of the P1 module itself, including all pins:

P1 Reference Design Schematic

Schematic - USB

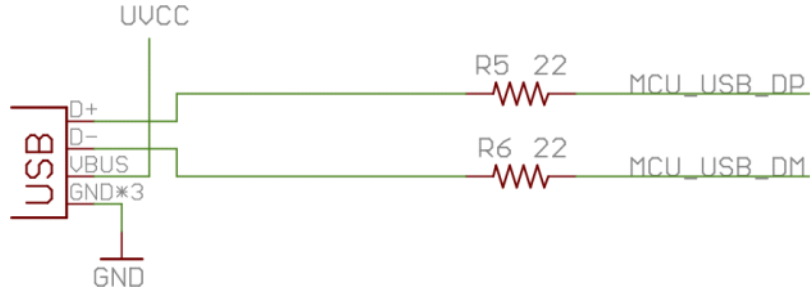

Schematic - Power

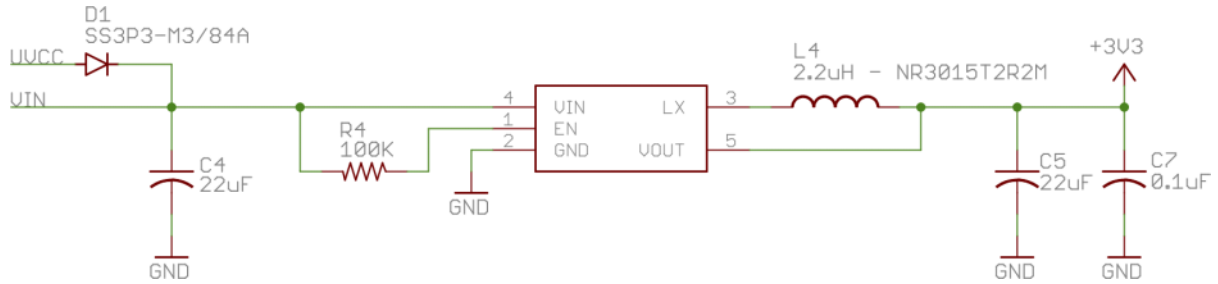

Schematic - User I/O

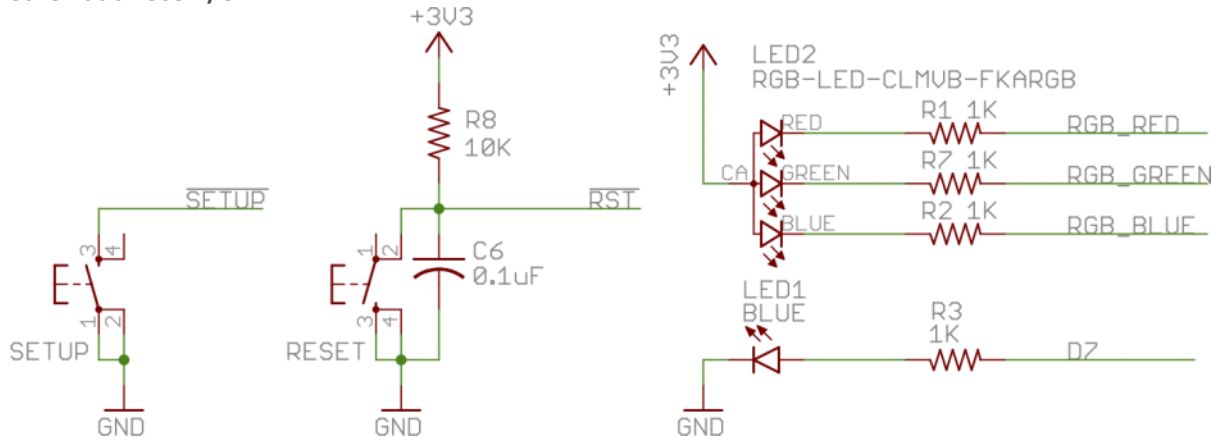

Schematic - P1 Wi-Fi Module

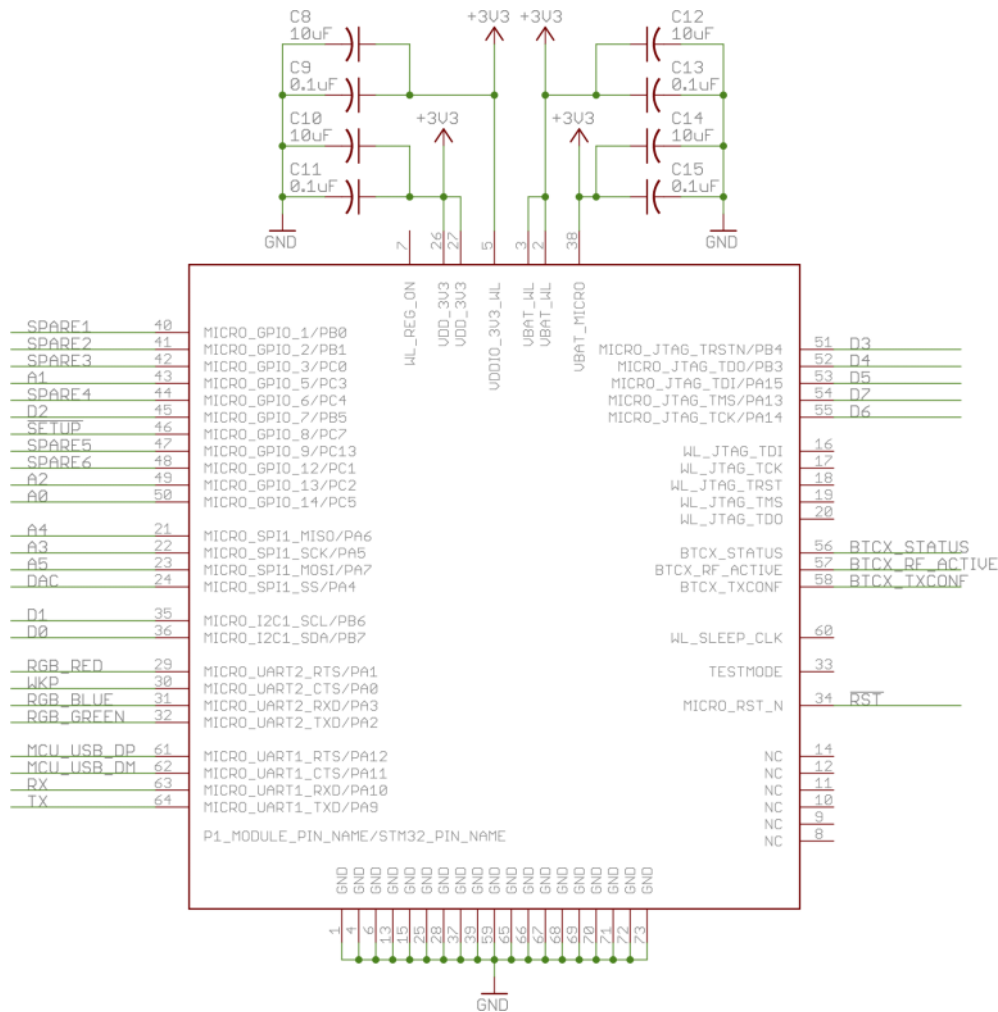

P1 Reference Design Layout

P1 Reference Design Top Layer (GTL)

To be added.

P1 Reference Design Bottom Layer (GBL)

To be added.

Recommended solder reflow profile

TEMP (°C)

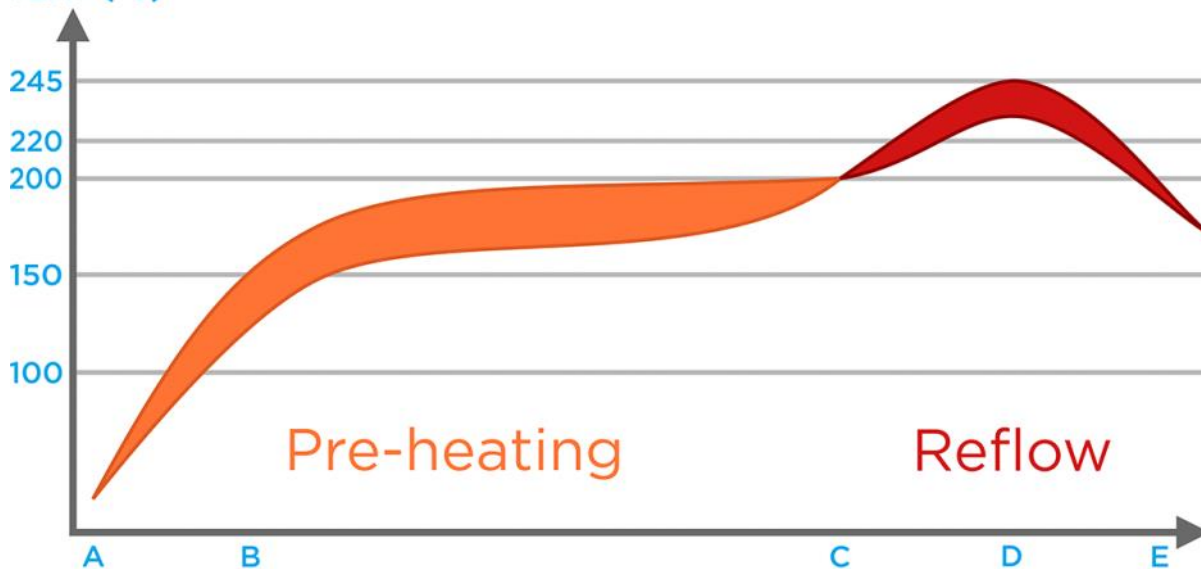

Phase	Temperatures and Rates
-------	------------------------

A-B.	Ambient~150°C, Heating rate: < 3°C/s
B-C.	150~200°C, soak time: 60~120 s
C-D.	200~245°C, Heating rate: < 3°C/s
D.	Peak temp.: 235~245°C, Time above 220°C: 40~90 s
D-E.	245~220°C, Cooling rate: < 1°C/s

Ordering information

P1 modules are available from store.particle.io as cut tape in quantities of 10 each.

Qualification and approvals



- RoHS
- CE
- FCC ID: COFWMNBM11
- IC: 10293A-WMNBM11

Product handling

Tape and Reel Info

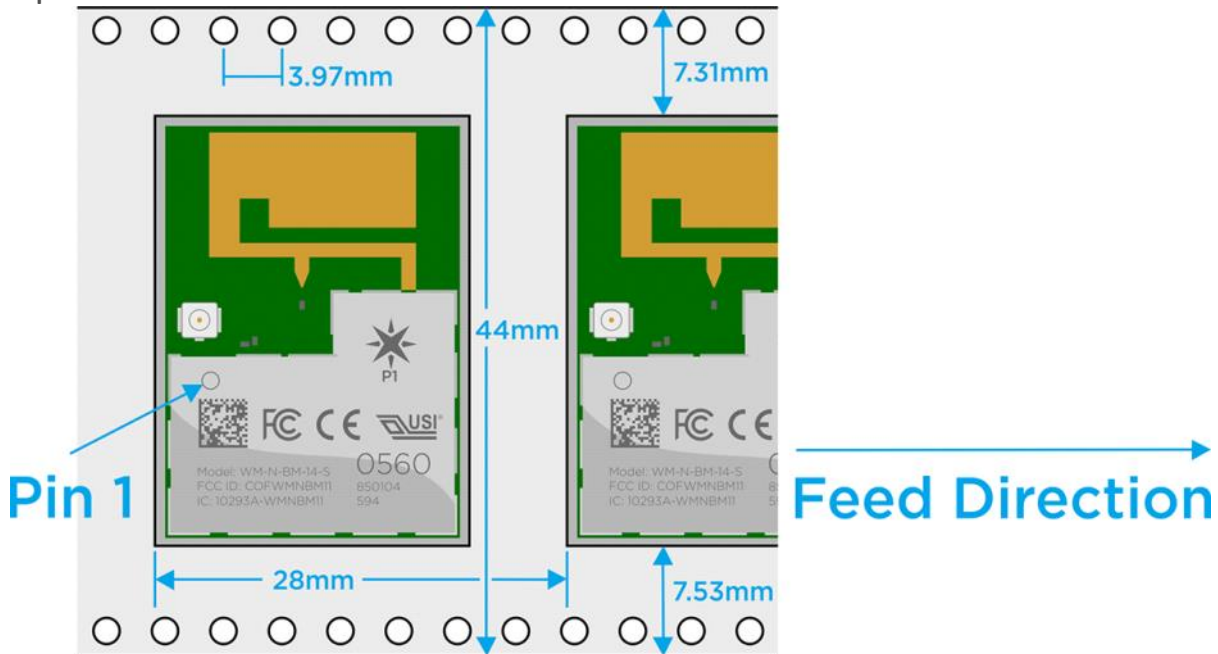

Moisture sensitivity levels

The Moisture Sensitivity Level (MSL) relates to the packaging and handling precautions required. The P1 module is rated level 3. In general, this precaution applies for Photons without headers. When reflowing a P1 directly onto an application PCB, increased moisture levels prior to reflow can damage sensitive electronics on the P1. A bake process to reduce moisture may be required.

For more information regarding moisture sensitivity levels, labeling, storage and drying see the MSL standard see IPC/JEDEC J-STD-020 (can be downloaded from www.jedec.org).

ESD Precautions

The P1 module contains highly sensitive electronic circuitry and is an Electrostatic Sensitive Device (ESD). Handling a P1 module without proper ESD protection may destroy or damage it permanently. Proper ESD

handling and packaging procedures must be applied throughout the processing, handling and operation of any application that incorporates P1 modules. ESD precautions should be implemented on the application board where the P1 module is mounted. Failure to observe these precautions can result in severe damage to the P1 module!

Default settings

The P1 module comes preprogrammed with a bootloader and a user application called Tinker. This application works with an iOS and Android app also named Tinker that allows you to very easily toggle digital pins, take analog and digital readings and drive variable PWM outputs.

The bootloader allows you to easily update the user application via several different methods, USB, OTA, Serial Y-Modem, and also internally via the Factory Reset procedure. All of these methods have multiple tools associated with them as well.

You may use the online Web IDE [Particle Build](#) to code, compile and flash a user application OTA (Over The Air). [Particle Dev](#) is a local tool that uses the Cloud to compile and flash OTA as well. There is also a package Spark DFU-UTIL for Particle Dev that allows for Cloud compiling and local flashing via DFU over USB. This requires dfu-util to be installed on your system. 'dfu-util' can also be used with [Particle CLI](#) for Cloud compiling and local flashing via the command line. Finally the lowest level of development is available via the [GNU GCC toolchain for ARM](#), which offers local compile and flash via dfu-util. This gives the user complete control of all source code and flashing methods. This is an extensive list, however not exhaustive.

Glossary

Radio Frequency

SMT

Surface Mount Technology (often associated with SMD which is a surface mount device).

AP

Access Point

USB

Universal Serial Bus

Quiescent current

Current consumed in the deepest sleep state

FT

Five-tolerant; Refers to a pin being tolerant to 5V.

3V3

+3.3V; The regulated +3.3V supply rail. Also used to note a pin is only 3.3V tolerant.

RTC

Real Time Clock

OTA

Over The Air; describing how firmware is transferred to the device.

FCC IC CE Warnings and End Product Labeling Requirements

Federal Communication Commission Interference Statement This equipment has been tested and found to comply with the limits for a Class B digital device, pursuant to Part 15 of the FCC Rules. These limits are designed to provide reasonable protection against harmful interference in a residential installation. This equipment generates, uses and can radiate radio frequency energy and, if not installed and used in accordance with the instructions, may cause harmful interference to radio communications. However, there is no guarantee that interference will not occur in a particular installation. If this equipment does cause harmful interference to radio or television reception, which can be determined by turning the equipment off and on, the user is encouraged to try to correct the interference by one of the following measures:

- Reorient or relocate the receiving antenna.
- Increase the separation between the equipment and receiver.
- Connect the equipment into an outlet on a circuit different from that to which the receiver is connected.
- Consult the dealer or an experienced radio/TV technician for help.

FCC Caution: Any changes or modifications not expressly approved by the party responsible for compliance could void the user's authority to operate this equipment. This device complies with Part 15 of the FCC Rules.

Operation is subject to the following two conditions:

1. This device may not cause harmful interference, and
2. This device must accept any interference received, including interference that may cause undesired operation.

FCC Radiation Exposure Statement: This equipment complies with FCC radiation exposure limits set forth for an uncontrolled environment. This transmitter module must not be co-located or operating in conjunction with any other antenna or transmitter. This End equipment should be installed and operated with a minimum distance of 20 centimeters between the radiator and your body.

IMPORTANT NOTE: In the event that these conditions can not be met (for example certain laptop configurations or co-location with another transmitter), then the FCC authorization is no longer considered valid and the FCC ID can not be used on the final product. In these circumstances, the OEM integrator will be responsible for re-evaluating the end product (including the transmitter) and obtaining a separate FCC authorization.

End Product Labeling The final end product must be labeled in a visible area with the following:

Contains FCC ID: 2AEMI-PHOTON

Manual Information to the End User The OEM integrator has to be aware not to provide information to the end user regarding how to install or remove this RF module in the user's manual of the end product which integrates this module.

Canada Statement This device complies with Industry Canada's licence-exempt RSSs. Operation is subject to the following two conditions:

1. This device may not cause interference; and
2. This device must accept any interference, including interference that may cause undesired operation of the device.

Le présent appareil est conforme aux CNR d'Industrie Canada applicables aux appareils radio exempts de licence.

L'exploitation est autorisée aux deux conditions suivantes:

1. l'appareil ne doit pas produire de brouillage;
2. l'utilisateur de l'appareil doit accepter tout brouillage radioélectrique subi, même si le brouillage est

susceptible d'en compromettre le fonctionnement.

Caution Exposure: This device meets the exemption from the routine evaluation limits in section 2.5 of RSS102 and users can obtain Canadian information on RF exposure and compliance. Le dispositif répond à l'exemption des limites d'évaluation de routine dans la section 2.5 de RSS102 et les utilisateurs peuvent obtenir des renseignements canadiens sur l'exposition aux RF et le respect.

The final end product must be labelled in a visible area with the following: The Industry Canada certification label of a module shall be clearly visible at all times when installed in the host device, otherwise the host device must be labelled to display the Industry Canada certification number of the module, preceded by the words "Contains transmitter module", or the word "Contains", or similar wording expressing the same meaning, as follows:

Contains transmitter module IC: 20127-PHOTON

This End equipment should be installed and operated with a minimum distance of 20 centimeters between the radiator and your body. Cet équipement devrait être installé et actionné avec une distance minimum de 20 centimètres entre le radiateur et votre corps.

The end user manual shall include all required regulatory information/warning as shown in this manual.

Revision history

Revision	Date	Author	Comments
v001	4- May-2015	BW	Initial release
v002	31- May-2015	BW	Update assets
v003	1- June-2015	BW	Updated VBAT_MICRO info
v004	24- July-2015	BW	Added FCC IC CE Warnings and End Product Labeling Requirements, Updated power output, added approved antennas, Corrected DAC2 as A3, Corrected A0 as pin 50, Corrected External Coexistence Interface pin numbers, Added RGB LED, SETUP and RESET button section.
v005	11- April-2016	BW	Added: full STM32 part number, Memory map, DAC limits, SWD pin locations, max source/sink current, known errata URL and tape-and-reel dimensions. Updated: BT COEX info, pinout diagrams (fixed RESET pin number error), operating conditions, pin descriptions (P1S0~P1S5 pins), land-pattern image signal keepout note.

Known Errata

We are tracking [known errata with this datasheet here](#). These issues/errors in the datasheet will be resolved in subsequent revisions.

Contact

Web

<https://www.particle.io>

Community Forums

<https://community.particle.io>

Email

hello@particle.io

Inserted from <<https://docs.particle.io/datasheets/p1-datasheet/>>